

RHG Roller Heavy Duty Gravity Conveyors

The RHG family of gravity roller conveyors is specifically designed to handle medium to heavy loads especially pallets of up to 3 tons. They are virtually maintenance-free and are manually operated thus require no energy.

Factory :New Borg El Arab 2nd Zone
entrance 2c street 3 - entrance 2c street 5
Tel:+20-(03)-4624127 - 4624126 - 4624025
fax : (03) 4624291

Info@UnitelEgypt.com

Cairo Office : Corniche El Nile, Maadi, Cairo
Tel +20:(0)2-25266333
Fax +20:(0)2-25264888

Sales@UnitelEgypt.com



www.UnitelEgypt.com



[/UnitelEgypt](#)

RHG Roller Heavy Duty Gravity Conveyors

Features

RHG Roller Gravity Conveyors are heavy duty conveyors that offer cost effective, safe and virtually maintenance-free handling of any goods with a suitable contact surface.

They feature galvanized 89 mm rollers mounted on a precision made frame. Rollers are set low for guided transport of goods smaller than the conveyor's nominal width.

The frame can accept many accessories such as guide rails, end stops, and can also be coupled through butt coupling plates to other conveyors such as the RDS family of live roller conveyors, and CHT heavy duty chain conveyors.



Characteristics

The RHG family of conveyors uses R89 rollers with female threaded shafts.

The heavy duty precision side frames are made of heavy gauge sheet metal.

The conveyors accept heavy duty supports of the SGH family.

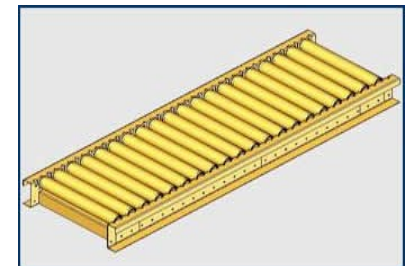

Applications

These heavy duty conveyors are used for transporting unit goods such as pallets, boxes, cartons, unit loads with a flat contact surface.

They can be used as stand alone conveyors in warehousing systems, or production lines, or in conjunction with RDS live roller conveyors and CHT chain conveyors.



RHG Roller Heavy Duty Gravity Conveyors

Specifications

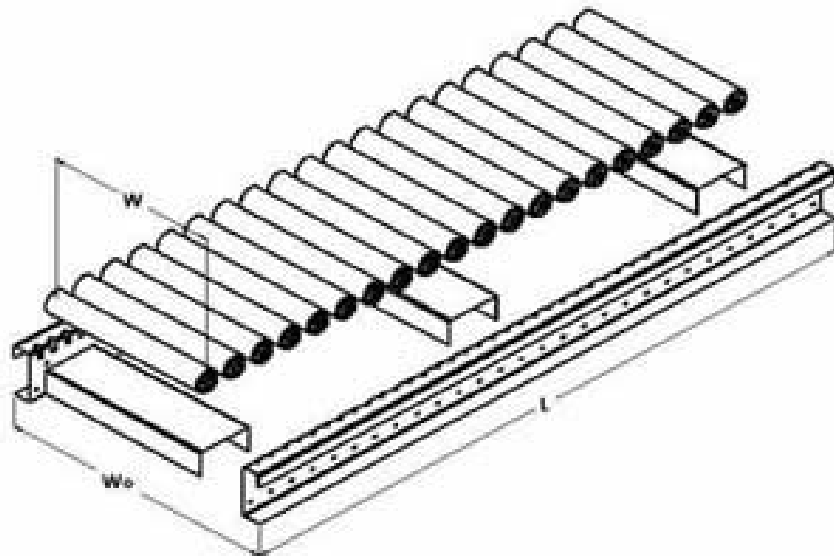

Loading Capacity	14,000 N/m
Roller Diameter	89 mm.
Roller Pitch	120 mm.
Linear Speed	Max 15 m/min.
Paint	Electrostatic Epoxy Powder RAL 5017or RAL 7035

RHG Roller Heavy Duty Gravity Conveyors



مكتب القاهرة : برج القاتوينين كورنيش المعادى
تليفون : ٠٢/٢٥٢٦٦٣٣٣
فاكس : ٠٢/٢٥٢٦٤٨٨٨

مدينة برج العرب الجديدة - المنطقة الصناعية الثانية
يونيتل/ مدخل ٢ شارع ٣ - مدخل ٢ شارع ٥
تليفون : ٠٣/٤٦٢٤٤٢٤-٤٦٢٤٠٢٥-٤٦٢٤١٢٦-٤٦٢٤١٢٧
فاكس : ٠٣/٤٦٢٤٢٩١



www.UnitelEgypt.com



/UnitelEgypt

Sales@UnitelEgypt.com

Info@UnitelEgypt.com